

# THE EFFECT OF THE EARTH'S ROTATION ON THE VELOCITY OF LIGHT

## PART II

BY A. A. MICHELSON AND HENRY G. GALE  
ASSISTED BY FRED PEARSON

### ABSTRACT

*Experimental Test of Theory.*—Air was exhausted from a twelve-inch pipe line laid on the surface of the ground in the form of a rectangle 2010×1113 feet. Light from a carbon arc was divided at one corner by a thinly coated mirror into direct and reflected beams, which were reflected around the rectangle by mirrors at the corners. The two beams returning to the original mirror produced interference fringes. The beam traversing the rectangle in a counter-clockwise direction was retarded. The observed displacement of the fringes was found to be  $0.230 \pm .005$ , agreeing with the computed value  $0.236 \pm .002$  within the limits of experimental error.

A rectangular tract of land at Clearing, Illinois, 2010 feet from east to west and 1113 feet from north to south, was carefully surveyed and staked by Dr. Kannenstine, and twelve-inch water pipes were laid straight and level around the entire circuit with a double line across one end.

The general plan of the arrangement is shown in Figure 1. Cast-iron boxes at the corners contained the mirrors. Figure 2 shows the details of one of the corner boxes. Delicate screw-and-lever systems, operated from outside the boxes through carefully fitted beveled joints, rendered it possible to adjust the mirrors readily about horizontal or vertical axes. The boxes were set in heavy concrete piers, and connected to the pipes by flexible joints of canvas and rubber. Similar joints were inserted in the pipe lines, about four hundred feet apart, and served as expansion joints.

The plane-parallel plates at *A* and *B* were lightly coated with gold, and that at *C* with silver, to reflect and transmit the desired proportions of light. The mirrors at *D*, *E*, and *F* were heavily silvered. A telephone system, consisting of portable sets kindly loaned by the Chicago Telephone Company, made it possible for an observer at *A* to direct assistants, one at each corner, when an adjustment of the mirrors was necessary. A Worthington air-pump, driven by a

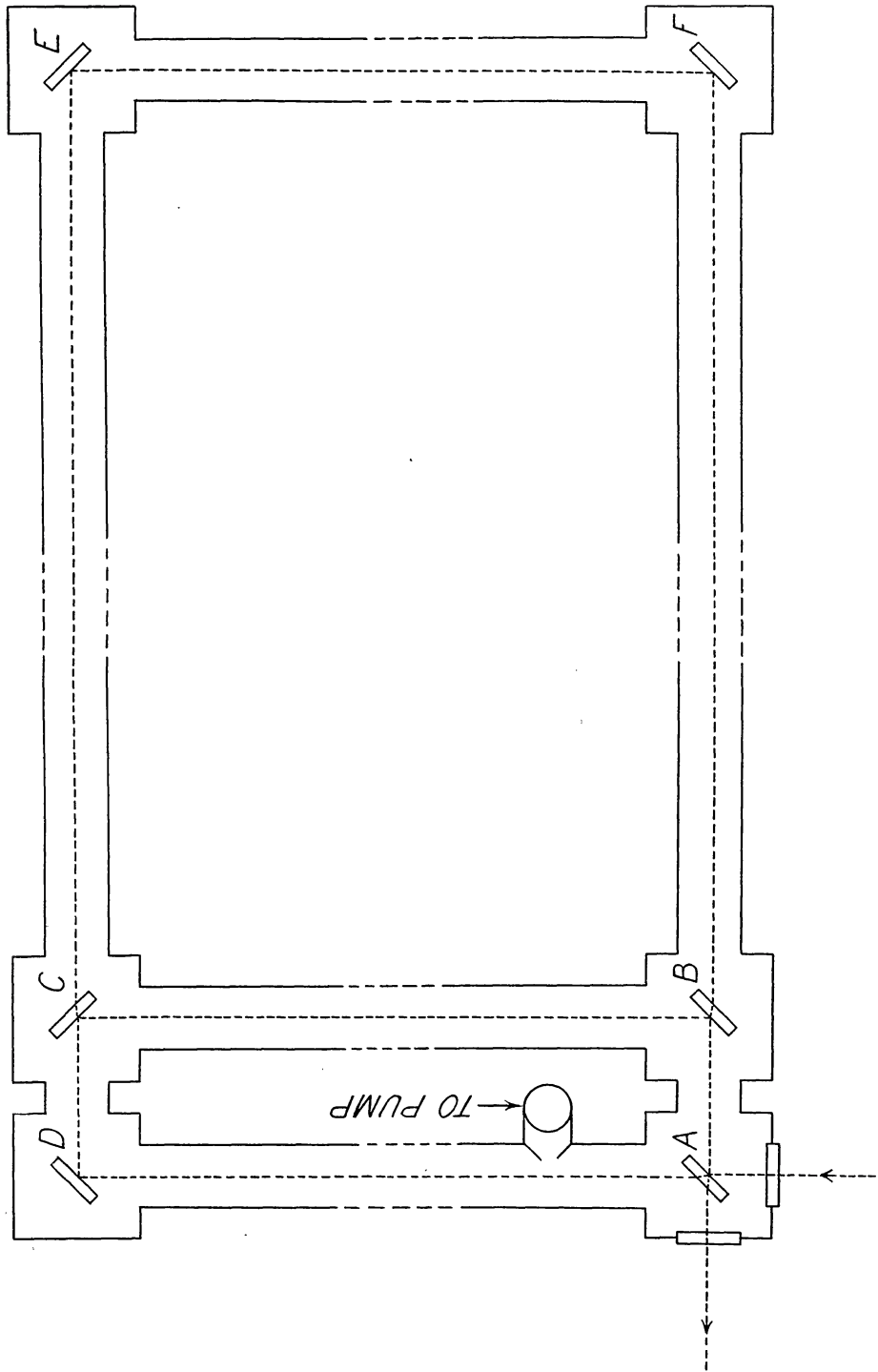

FIG. 1.—Ground plan, showing arrangement of mirrors

50 horse-power motor, reduced the pressure in the pipe to about a half-inch in three hours. Most of the measurements were made when the residual air in the pipes had been reduced to a pressure of about half an inch to one inch of mercury. At these pressures the fringes were perfectly steady, and as sharply defined as could be desired.

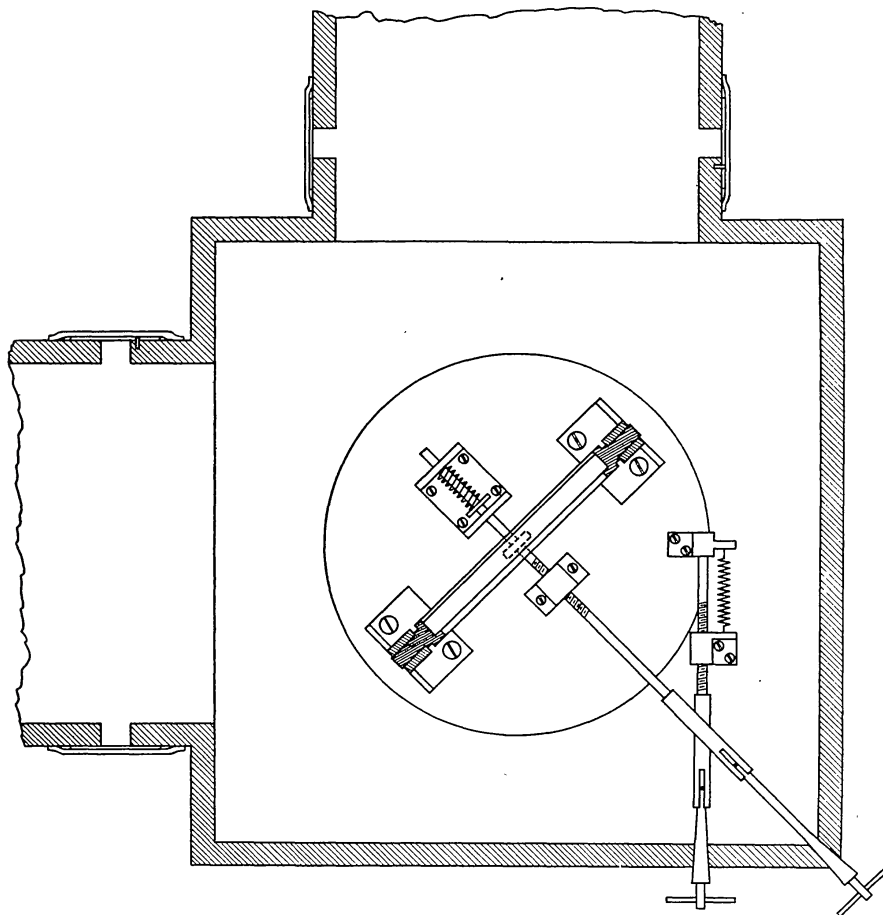

FIG. 2.—Details of corner box and mirror mounting

The fringes to be measured were those formed by the beams going in opposite directions about the circuit *ADEF*. As a fiducial mark from which to measure the displacement, a second set of fringes was formed by the mirror system *ABCD*. The area inclosed by this circuit was much too small to give a measurable displacement of the fringes, and the shifts actually recorded were those between the central fringes of the two sets.

In general the two sets of fringes will not coincide in position, entirely aside from any question of ether drift or the earth's rotation, unless the two direct images and the two reflected images of the source are exactly superposed. The central fringes of the set formed by the mirrors of the short circuit will be halfway between the direct and reflected images of the source, and the central fringe of the long line would be halfway between the direct and reflected images if there were no difference due to the earth's rotation.

To correct for any lack of superposition of the two sets of rays, the observing telescope (a six-inch achromatic objective, and two-inch micrometer eyepiece) was focused on the images of the source (arc or slit) and the apparent displacement of the central fringe of the long circuit, compared with the central fringe of the short circuit, was corrected by an amount equal to the difference in the mean positions of the two images for the two light circuits. The fringes are most conveniently observed in the overlapping cones of light an inch or so inside or outside of the focal plane.

About half of the determinations were made with the arc placed directly in front of the window at *A*, and about half with a condensing lens, slit, and collimating lens. The second arrangement gave much more light than the first, but there was no apparent difference in the measured displacements.

The calculated value of the displacement on the assumption of a stationary ether as well as in accordance with relativity is

$$\Delta = \frac{4A \omega \sin \phi}{\lambda V}$$

where  $\Delta$  is the displacement in fringes,  $A$  the area in square kilometers,  $\phi$  the latitude ( $41^{\circ}46'$ ),  $V$  the velocity of light,  $\omega$  the angular velocity of the earth, and  $\lambda$  the effective wave-length of the light used. Measurements were made in the laboratory, comparing the fringes produced by the same set of mirrors and the same 20-ampere alternating-current arc, with fringes produced by sodium light from a bit of glass in an oxyhydrogen flame. The light from the arc was reduced to approximately the same intensity as in the experiment at Clearing, by transmitting it through a rather narrow slit in a

rotating disk. The mean of ten determinations gave  $\lambda = 5700 \pm 50$  angstroms.

The displacement of the fringes due to the earth's rotation was measured on many different days, with complete readjustments of the mirrors, with the reflected image sometimes on the right and sometimes on the left of the transmitted image, and by different observers. The deflections were averaged usually in sets of twenty, in the order in which they were taken. The resulting means are given in Table I. The entire set of two hundred and sixty-nine determina-

TABLE I

Observation*	Displacement in Fringes	Number of Observations	Deviation from Mean
1.....	0.252	20	0.022
2.....	.255	20	.025
3.....	.193	20	.037
4.....	.246	20	.016
5.....	.235	20	.005
6.....	.207	26	.023
7.....	.232	20	.002
8.....	.230	20	.000
9.....	.217	20	.013
10.....	.198	20	.032
11.....	.252	20	.022
12.....	.237	20	.007
13.....	0.230	23	0.000
	Mean 0.230	Total 269	Av. dev. from Mean 0.016

\* Observations 1 and 2 corrected for direct image only; 1-6 inclusive, without collimator; 7-13 inclusive, with collimator.

	Obs.	Calc.
Displacement.....	0.230 $\pm$ .005	0.236 $\pm$ .002

tions and their distribution about the mean value is shown graphically in Figure 3. The final displacement, expressed as a fraction of a fringe, is

0.230  $\pm$  .005 obs.      0.236  $\pm$  .002 calc.

In view of the difficulty of the observations, this must be taken to mean that the observed and calculated shifts agree within the limits of observational error.

The successful completion of this experiment is due in no small measure to the friendly co-operation of the officials of the City of

Chicago, Colonel A. A. Sprague, commissioner of public works; Mr. H. L. Lucas, superintendent of the Water Pipe Extension Division, and to Mr. B. W. Cullen, superintendent of the South District of the same Division; to the courtesy of the Clearing

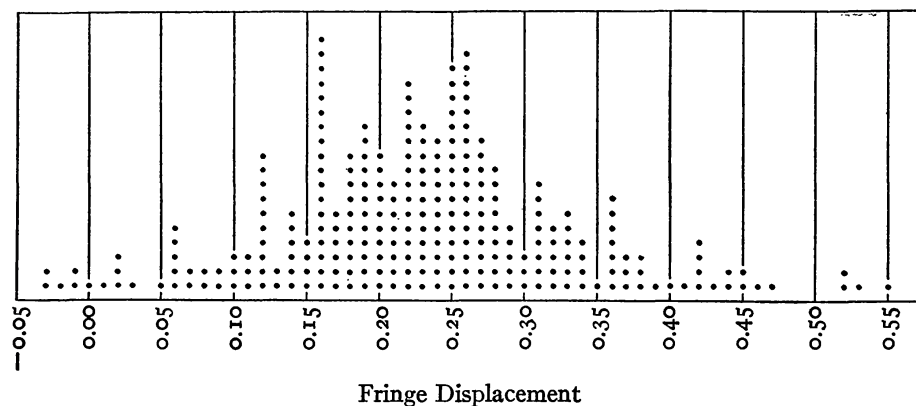

FIG. 3.—Distribution of observations

Industrial District, through Mr. Henry H. Porter; to the kindness of the Chicago Telephone Company, and to the hearty and enthusiastic support of the University. We are especially indebted to President Burton, Mr. J. C. Dinsmore, Mr. L. R. Flook, and to Messrs. Thomas O'Donnell, Joseph Purdy, and Charles Stein.

RYERSON PHYSICAL LABORATORY  
UNIVERSITY OF CHICAGO  
March 1925