

GALACTIC RADIATION AT RADIO FREQUENCIES

V. THE SEA INTERFEROMETER

By J. G. BOLTON* and O. B. SLEE*

[*Manuscript received June 11, 1953*]

Summary

The factors involved in the study of discrete sources of galactic noise by the sea interferometer are discussed. Three new forms of sea interferometer which increase the effectiveness of this technique are described.

I. INTRODUCTION

Owing to the low resolving power of metre wavelength aerial systems of reasonable physical dimensions, interference methods have been widely used in the study of radio-frequency emission from the Sun and stars. Two forms of interferometer have been employed, the sea interferometer and the two-aerial interferometer. The former depends on interference between the direct ray from a source and the ray reflected from the sea at an aerial situated on the top of a cliff. This system is analogous to Lloyd's mirror in optics. The other, consisting of two aerials spaced many wavelengths apart along an east-west base line, may be compared to the Michelson interferometer. The relative advantages of the two systems have been previously discussed (Stanley and Slee 1950) but will be briefly reviewed.

One inherent advantage of the sea interferometer is that twice the sensitivity is achieved with a single aerial as with two similar aerials in the other system. Further, no interconnecting cables or preamplifiers are required. Probably the most important advantage is due to the "cut-off" of the sea's horizon. The interference pattern commences sharply as a source rises above the horizon, in contrast to a gradual "fading-in" in the two-aerial interferometer. This feature is most useful in resolving two or more close sources.

Variable refraction adversely affects the sea interferometer in its use for determining accurate source positions and the curvature of the Earth produces effects which restrict its use for measuring angular widths. The two-aerial interferometer is not affected by the Earth's curvature and the effects of atmospheric refraction and scintillation are much smaller than in the sea interferometer. The effects of refraction on sea interference measurements of position can be overcome by taking observations over a sufficiently long period and by calibrating the instrument on sources of known position. Scintillations, which are most severe at low angles of incidence, affect the "seeing" of very weak sources.

* Division of Radiophysics, C.S.I.R.O., University Grounds, Sydney.

The best results are obtained near the equinoxes and in the few hours about dawn when scintillations are rarely observed.

The major disadvantage of the sea interferometer is that it is inherently a "total noise" measuring system. The output of the receiver consists of the sum of four components: (1) the noise generated in the receiver itself, (2) the integrated background noise from that part of the sky in the acceptance cone of the aerial, (3) the noise received from the discrete source under observation, and in some cases (4) unwanted signals of terrestrial origin. In certain regions component (2) changes more rapidly than the amplitude of the interference pattern due to the discrete source. The procedure until recently has been to balance out the greater part of the total noise and amplify the remainder in a D.C. amplifier for presentation on a recording milliammeter. It was necessary for the operator to adjust the D.C. amplifier as the change in component (2) from the changing background noise caused the recorder to go off scale. Obtaining records of the discrete sources was thus very laborious and, in addition, the interpretation of the records was often difficult. In the two-aerial interferometer with a phase switching system as described by Ryle (1952) the interference fringe system is switched alternately between two positions half a fringe width apart, a synchronous rectifier being used to detect the difference in receiver output between the two positions. With such an arrangement components (1) and (2) are eliminated from the recorded output and in some cases component (4). Only the difference between the signal from the source in the two positions of the fringe system is recorded and this changes in a sinusoidal manner as the position of the source changes.

Recently several modifications have been made to the simple sea interferometer which reduce or eliminate the effects of the varying background component and greatly increase the sensitivity and ease of operation of the equipment. The first part of this paper gives an account of the physical factors affecting sea interference patterns and the second part describes some of these new techniques.

II. FACTORS WHICH GOVERN SEA INTERFERENCE PATTERNS

(a) *General*

When a discrete source, rising above the sea horizon, is observed with an aerial and receiving equipment situated on a high cliff an interference pattern is obtained. The interference occurs as the path difference between the direct ray and the ray reflected from the surface of the sea changes with the altitude of the source. It can be shown that, under idealized conditions, the fringe system for a point source is given by

$$P = 2P_0 \left(1 - \cos \frac{4\pi h \sin \alpha}{\lambda} \right),$$

where P is the power received,

P_0 is the power received with the same aerial in free space,

h is the height of the aerial above the sea,

λ is the wavelength,

α is the altitude of the source.

Interference minima and maxima occur when $4\pi h \sin \alpha/\lambda = 2n\pi$ and $(2n+1)\pi$ respectively, where n is the fringe number. The amplitude of the pattern is given by

$$P_{max} - P_{min} = 4P_0.$$

In actual practice the amplitude is governed by a number of different factors, some of which are due to the geometry of the system and others to the characteristics of the receiving equipment. The expression for the amplitude may be written

$$P_{max} - P_{min} = 4P_0 F(z, \alpha) \cdot F_r(\alpha) \cdot F_b(n) \cdot F_c(\alpha, h) \cdot F_w(n),$$

where $F(z, \alpha)$ represents the aerial sensitivity pattern—a function of altitude and azimuth,

$F_r(\alpha)$ is the factor due to imperfect reflection from the surface of the sea—a function of altitude,

$F_b(n)$ is the factor due to finite bandwidth of the receiver—a function of the fringe number,

$F_c(\alpha, h)$ is the factor due to the divergence in the reflected rays at the curved surface of the Earth,

$F_w(n)$ is a factor due to a combination of the effect of sea waves and the time constant of the recording system.

The various factors may be considered as independent. The factors due to the aerial sensitivity pattern and the receiver bandwidth can obviously be treated separately from the others which are governed by conditions at reflection. The factor due to the reflection coefficient is considered as arising from the physical properties of the sea-water, whereas the curvature factor is due to the divergence of the reflected beam. The curvature factor is only important near grazing incidence, whereas the effect of sea waves is negligible at grazing incidence and important for high fringe numbers.

$F(z, \alpha)$ depends on the aerial used in a particular system and will not be further discussed. Formulae covering the other factors and examples of particular cases will be given in Sections II (b)-(f) following.

(b) *The Reflection Coefficient of the Sea*

The formulae of Section II (a) assume that the reflection coefficient of the sea is unity. With a reflection coefficient of $r < 1$,

$$P = P_0(1 + r^2 + 2r \cos \Delta),$$

where Δ is the phase difference between the direct and reflected rays.

The maximum and minimum values are $P_0(1+r)^2$ and $P_0(1-r)^2$. Thus the reduction factor due to the reflection coefficient

$$\begin{aligned} F_r(\alpha) &= \frac{P_{max} - P_{min}}{4P_0} \\ &= r. \end{aligned}$$

Theoretical values of the reflection coefficients for vertically and horizontally polarized waves are given by Massachusetts Institute of Technology Radar

School (1946). For horizontally polarized waves the sea behaves like a perfect reflector and r does not differ sensibly from unity up to altitudes of 10° . For vertically polarized waves the sea behaves more like a dielectric and the reflection coefficient departs appreciably from unity. At 100 Mc/s it falls to a value of 0.4 for an angle of incidence corresponding to an altitude of the source of 2.5° .

It is evident that horizontal polarization is to be preferred for sea interferometry, particularly as the phase change on reflection remains constant at π for a wide range of angles of incidence. Observations on the discrete sources confirm the value of unity for horizontal polarization. However, the value obtained for the coefficient of reflection for vertically polarized waves is 0.7 instead of 0.4 at its minimum near 2° .

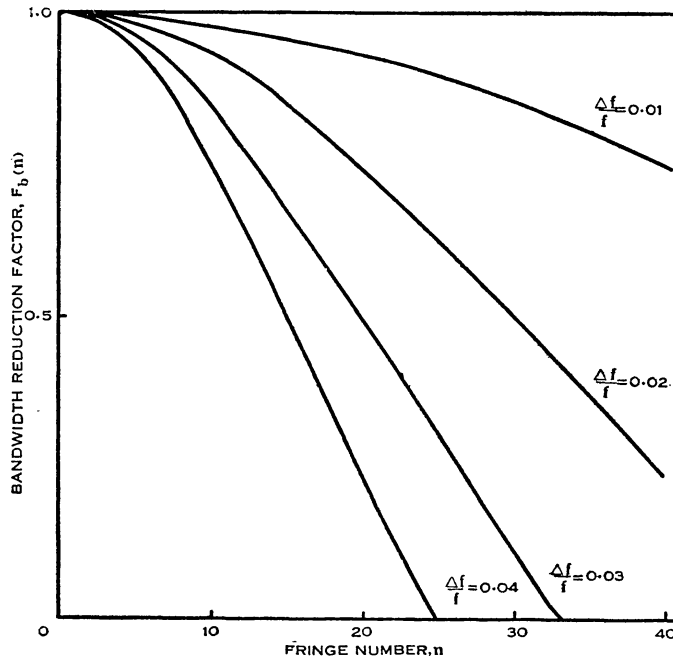

Fig. 1.—Curves showing the effect of receiver bandwidth with increasing fringe number on the amplitude of interference fringes for four ratios of bandwidth to frequency.

(c) The Receiver Bandwidth

The effect of a finite receiver bandwidth on an interference pattern is similar to that in the optical case and results in decreasing fringe visibility with increasing fringe order. For the sea interference patterns the zero order fringe occurs when the source is first seen on the horizon. The theory of the effect of a finite receiver bandwidth has been given previously in Part II of this series (Stanley and Slee 1950). At the n th fringe it can be shown that, for $n < f/\Delta f$,

$$F_b(n) = \frac{\sin n\pi\Delta f/f}{n\pi\Delta f/f},$$

where Δf is the pass band of the receiver (assumed square in shape) and f is the wave frequency.

It will be seen that n and $\Delta f/f$ are interchangeable in the above expression ; thus, for particular values of n and $\Delta f/f$, $F_b(n)$ is the same as that for half the bandwidth and twice the fringe number and so on. Computed curves of the variation of $F_b(n)$ with fringe number for certain ratios of bandwidth to wave frequency are shown in Figure 1. It is clear that when large numbers of fringes are required—for example, for the determination of the position of a discrete source—the receiver bandwidth should be as small as possible. In other applications the use of a wide receiver bandwidth can be advantageous in suppressing unwanted high-order fringes. This has the effect of reducing the acceptance cone of an aerial as far as sources are concerned.

(d) *The Curvature of the Earth*

Although we speak of direct and reflected “ rays ”, any aerial has a finite absorption cross section or area and thus receives power from a source in a beam of this cross section. In reflection from a plane surface this beam is not changed but on reflection from a curved surface divergence of the beam occurs. This divergence in sea interferometry results in less power in the reflected beam and hence incomplete interference between it and the direct beam. The theory of the effect of the curved Earth has been developed in Part II of this series (Stanley and Slee 1950) and the amplitudes of the interference pattern at minima and maxima are given by

$$\frac{P_{min}}{2P_0} = \frac{\theta}{\frac{h}{R\theta} + \frac{3\theta}{2}},$$

$$\frac{P_{max}}{2P_0} = \frac{\frac{2h}{R\theta}}{\frac{h}{R\theta} + \frac{3\theta}{2}},$$

where R is the radius of the Earth and θ is the angular separation of the aerial and the point of reflection at the centre of the Earth.

Thus

$$\begin{aligned} F_c(\alpha) &= \frac{P_{max} - P_{min}}{4P_0} \\ &= \frac{1}{2} \cdot \frac{2h - R\theta^2}{R\theta \left(\frac{h}{R\theta} + \frac{3\theta}{2} \right)}. \end{aligned}$$

Since the forms of P_{max} and P_{min} are different, it is more convenient to study the variation of each of these quantities with height of aerial and altitude of source separately. The values of P_{max} and P_{min} are plotted in Figure 2 for four different values of aerial height, which cover the range that could be used in sea interferometry. It can be seen that the effect of the Earth's curvature persists to higher altitudes as the height of the aerial is increased. This limits the usefulness of the sea interferometer in the determination of angular widths of sources. Although the resolving power of the interferometer improves as the

height above the sea is increased and the fringe spacing decreased in consequence, the value of the ratio of the heights of the maxima and minima above the zero level is increasingly affected by the corrections for curvature. It is also clear that for greater aerial heights the sea interferometer loses one of its principal advantages in that the sharp cut-off due to the horizon disappears. The sharp cut-off is replaced by a gradual fading in of the interference pattern (the envelope is indicated by the difference between the curves of P_{max} and P_{min} in Figure 2). This effect is enhanced when atmospheric refraction is taken into account.

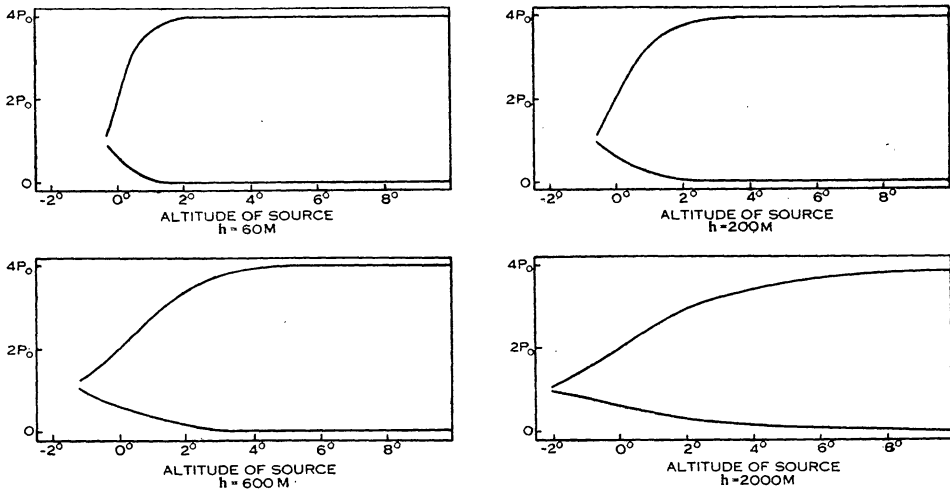

Fig. 2.—Curves showing the effect of the Earth's curvature on sea interference patterns for a range of aerial heights. The upper and lower curves in each diagram represent the variation in the heights of the interference maxima and minima with the altitude of the source. The actual patterns lie within the envelope formed by these curves.

(e) Sea Waves

On a ray theory treatment the area within which reflection takes place for a perfectly smooth sea is the projected area of the aerial system on the sea. This is $H \cot \alpha$ by B , where H and B are the height and breadth of the aerial. In a rough sea not all the radiation incident on this area is reflected towards the aerial and some radiation is reflected towards the aerial from regions outside this area. The phases of the various components are related to the Fresnel pattern on the sea. The dimensions of the first Fresnel zone in and perpendicular to the direction of the source can be shown to be

$$\frac{\lambda \cot \alpha}{\sin \alpha} \quad \text{and} \quad 2 \sqrt{\frac{h\lambda}{\sin \alpha}}$$

or

$$\frac{2h \cot \alpha}{n} \quad \text{and} \quad h \sqrt{\frac{8}{n}}$$

in terms of the fringe number. In a typical case, for a cliff height of 80 m and a wavelength of 3 m the dimensions of the first Fresnel zones for fringe numbers

E

2, 10, and 20 are 2300 by 160, 90 by 71, and 23 by 50 m. For an aerial of height 3 m and breadth 10 m the ideal reflection areas for the same fringe numbers are 85 by 10, 17 by 10, and 8 by 10 m.

There are two cases to be considered, one where the dimensions of the waves are small and one where the dimensions of the waves are large compared with the dimensions of the ideal reflection area and the Fresnel zones. The first occurs in a choppy sea and the second in a heavy swell. In the first case phase dispersion occurs in the reflected radiation owing to the dispersion in position of the reflecting regions in relation to the Fresnel zones and owing to the dispersion in heights. Both dispersions increase with the altitude of the source and the phase dispersion due to position may be quite considerable as the aerial beam width includes a number of zones. The effect of the phase dispersion is incomplete interference between the direct and reflected radiation and a decreasing visibility of the fringes with altitude. Observing experience has shown that a choppy sea has little effect on the visibility of the first 10 or so fringes so that for these fringes reflection must mainly occur within the first Fresnel zone.

On the other hand a heavy swell (of wavelength of the order of 100 m) has a marked effect on relatively low-order fringes. It appears in this case that a considerable part of the reflection area rises and falls as the successive crests and troughs cross the line of sight. The effect of this is to produce a secondary modulation of the basic interference pattern with the frequency of the sea waves, as illustrated in Figure 3. This effect on the low-order fringes is most marked

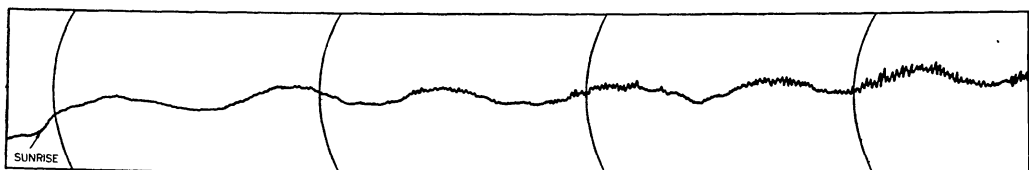

Fig. 3.—Sea interference pattern of the Sun rising showing the increasing effect of sea waves with fringe number. The curved scale lines represent intervals of 10 min. The slow sinusoidal variation is the interference pattern and the ripples are due to sea waves.

in the case of a swell crossing the line of sight of the source, probably because the reflection takes place mainly within the first Fresnel zone which includes part of only one wave. The modulation of the basic interference pattern by the waves is of an unusual type; the deflexions near the interference minima are positive and those near the maxima negative. Thus, if a large time constant is used at the output of the receiver to damp out the modulation, the amplitude of the pattern is reduced compared with that of an unmodulated pattern. The reduction in fringe visibility, which increases with the fringe number, is similar to that due to a finite receiver bandwidth. As the high-order fringes can be reduced by decreasing the beam width of the aerial in the vertical plane, both these effects may be considered as improving the resolving power of the aerial in observations on sources.

(f) Observing Experience and Typical Records

The present writers have used sea interference technique to study the variation of the flux density with frequency of a few major sources with relatively small aerials and in the search for large numbers of sources with a large single-

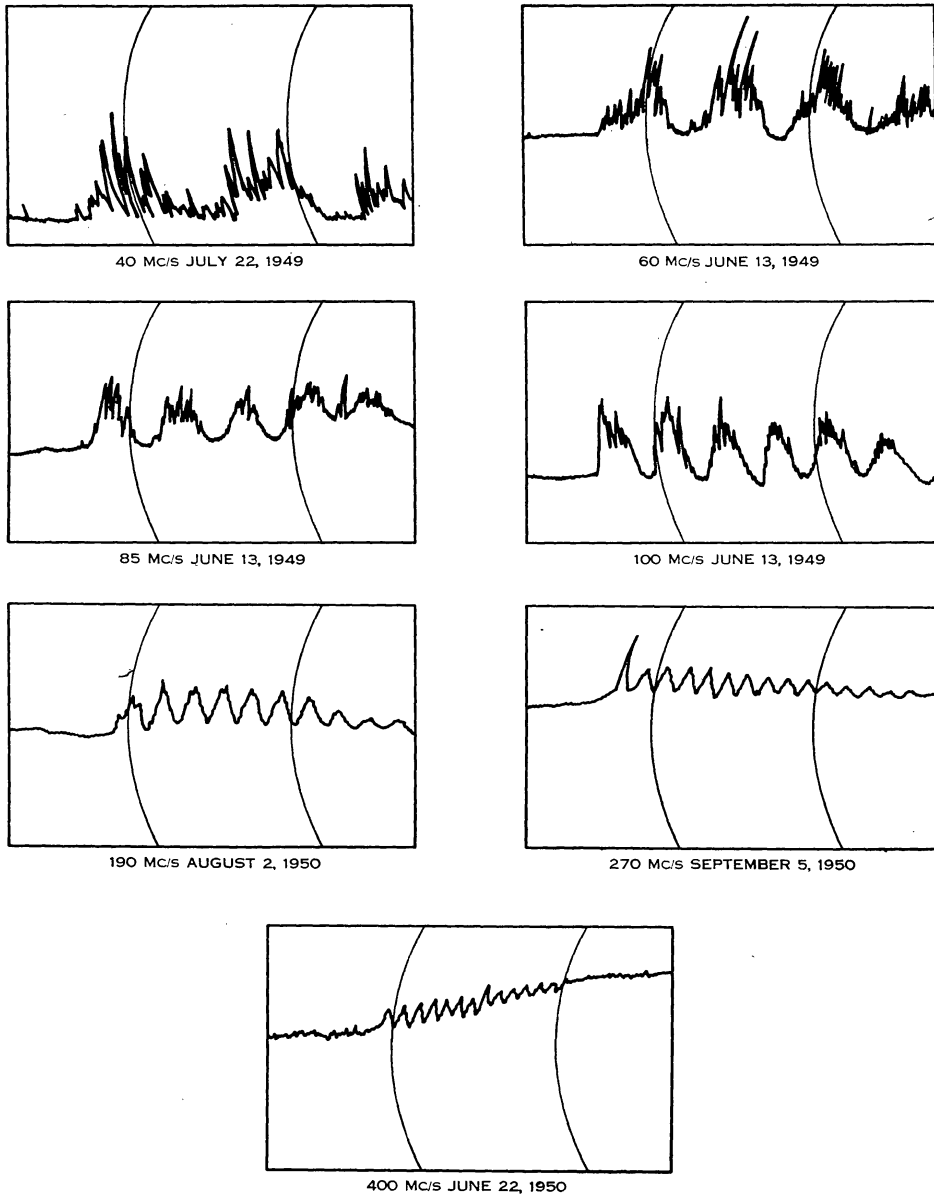

Fig. 4.—Sea interference records of the Cygnus source at rising at various frequencies between 40 and 400 Mc/s. Note the severity of the scintillations at 40 Mc/s and also the similarity of the scintillations on the 60, 85, and 100 Mc/s records which were obtained on the same day.

frequency aerial. The records shown in Figure 4 are examples of sea interference patterns of the Cygnus source at rising in the frequency range of 40–400 Mc/s. The records show that successful observations can be made in

this 10 : 1 range of frequencies. They also illustrate the variation of the scintillations with frequency, for, although not all the records were obtained on the same day, they are representative of the average behaviour on the different frequencies. At 100 Mc/s and above, reasonable estimates of the flux density of a source can be made at any time of the day or year. At 60 Mc/s accurate measurements are restricted to periods of low scintillation, while at 40 Mc/s useful observations are rarely obtained due to extreme scintillations and variations in atmospheric refraction.

Most of our measurements have been made from a height of 80 m although some observations have been made at heights ranging from 30 to 300 m. At heights of more than 300 m the effect of the Earth's curvature becomes increasingly important and this feature must always be considered in the selection of a site for observations.

No measurements have been made above 400 Mc/s. At our present site, and at this frequency the fringe period for a source of zero declination is only 1 min. This puts an upper limit of about 10 sec on the size of the time constant that can be used in the output of the receiver. The size of this time constant is one of the factors which determine the ultimate sensitivity of the receiving equipment, and the permissible time constant becomes increasingly important at high frequencies due to the rapid decrease in the flux densities of the sources with increasing frequency. However, with a lower site we consider that the sea interference technique could be used successfully for the observation of sources at frequencies as high as 1000 Mc/s.

III. NEW FORMS OF THE SEA INTERFEROMETER

(a) *Systems for Reducing the Effect of the Background Noise*

In general there are two possible ways of reducing or eliminating the effect of the varying background noise in an interference technique. The first is to use some form of electronic control in one or more stages of the receiver. The second depends on switching either the aerial beam or the interference fringes between different positions and detecting the difference in signals. Ryle (1952) has exploited the fringe switching (or phase switching) method in his two-aerial interferometer, but this system is not directly applicable to the sea interferometer as the positions of the fringes are determined solely by the geometry of the instrument. Three systems which have been used for reducing the effect of the background noise will be described in Sections III (b)-(d) following.

(b) *The Beam Switching System*

In this technique the aerial beam is directed alternately 25 times a second towards the horizon and towards an adjacent region of the sky away from the horizon. The aerial consists of two banks (Fig. 5) about $1\frac{1}{2}$ wavelengths apart. Connection to the receiver is made alternately at the mid point of the cable joining the two banks and a point $\frac{1}{4}$ wavelength away. With the banks connected in phase, the aerial beam is directed towards the horizon and the aerial receives the background noise in this direction and the signal from a source within the beam. With the banks connected out of phase, the aerial beam is directed away from the horizon and receives the background noise from an

adjacent region of the sky. In the out-of-phase connection the beam is actually split, the lower half being reflected from the sea, but a combination of various factors such as the roughness of the sea and a wide receiver bandwidth ensures that there is no interference within the beam.

The alternating component in the receiver output due to the beam switching is detected by a rectifier synchronized with the aerial switch. (This type of detector is subsequently referred to as a "synchronous rectifier", which is suggested as a more suitable alternative to "phase sensitive rectifier" used by other writers.) The efficiency of the beam switching system depends on the difference in levels between the background noise in the two positions of the switched beam. It has been found to be very effective in regions away from the galactic plane and also near the galactic plane between longitudes 300 and 60°, where the plane of the Galaxy rises almost perpendicular to the horizon.

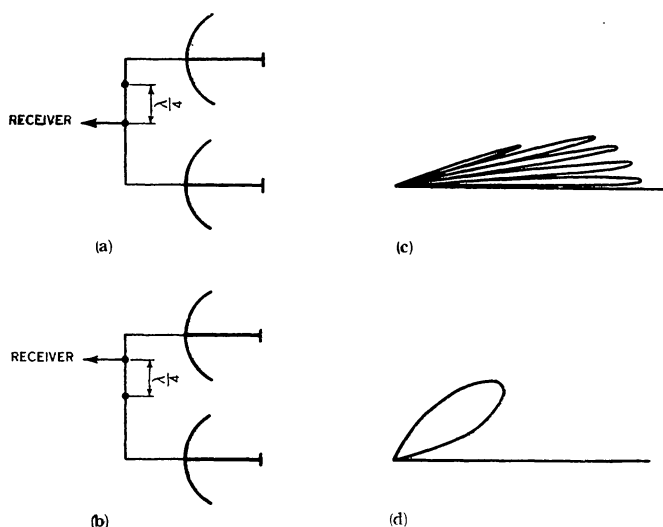

Fig. 5.—Illustrating the principle of the beam switching system for reducing the effect of the variation in background noise. (a) Aerials connected in phase; (b) aerials connected out of phase; (c) aerial beam directed towards horizon; (d) aerial beam directed away from horizon.

The beam switching system greatly reduces the effects of natural and man-made electrical disturbances as long as the source of the disturbance is not located entirely within one of the positions of the switched beams. It also offers the very useful possibility of being able to detect weak sources close to much stronger ones. With the sea interferometer weak sources can be detected until such time as a much stronger one rises above the horizon. A weak source rising shortly after a stronger one can sometimes be detected by the beating of the two interference patterns, but not when the ratio of the flux densities exceeds about 10:1. In the beam switching system, the in-phase and out-of-phase aerial diagrams overlap to some extent and thus at some altitude there is a null point in the switched pattern. This null point can be changed by changing

the lengths of the connecting cables. By using hand-operated or motor-driven variable lines it would be possible to keep a strong source in the null point after it had attained an altitude of, say, 3° and detect a weaker source at its rising.

(e) *Automatic Control of the Receiver Gain*

In this system the variations in the background noise are electronically suppressed. The principle of the system is shown in Figure 6. The upper diagram represents the normal output of the receiver, which is fed into an integrator. The output of the integrator roughly follows the input except that rapidly changing components such as the sinusoidal voltages due to discrete sources are smoothed out. The output of the integrator is then used to control the gain of some stage of the receiver, giving a resultant receiver output shown in the lower diagram of Figure 6.

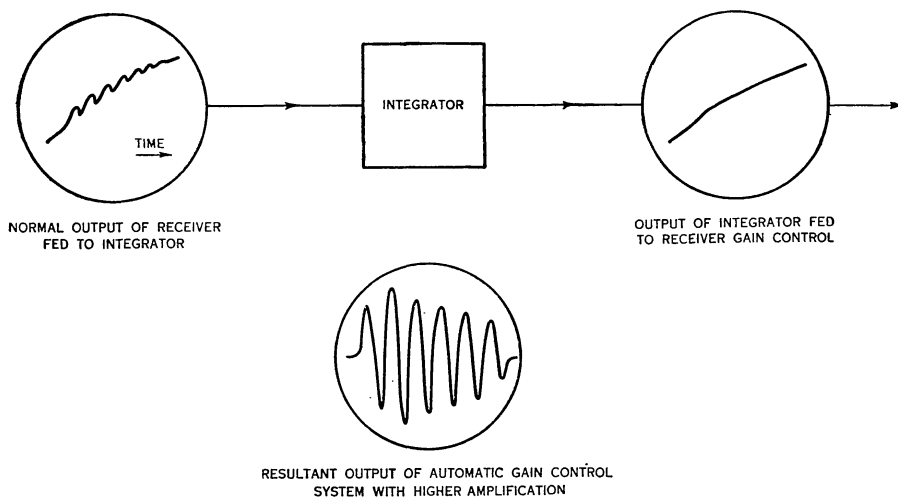

Fig. 6—Illustrating the principle of the automatic gain control system.

The integrator in use utilizes the "Miller" effect. It has three stages of highly stable D.C. amplification giving an overall gain of about 1500. In combination with a $1\text{ M}\Omega$ input resistance and a feedback condenser of $2\ \mu\text{F}$ this gives a time constant of about 40 min. The requirements of the integrator time constant depend on the degree of control of the background noise necessary for the section of the sky under observation. Greater control can be obtained by the use of short time constants but a time constant which is too short attenuates the interference patterns. It has been found that with a time constant of 40 min the variation in the background noise is reduced by a factor of 50–100, while the amplitudes of the interference patterns (5–10 min fringe periods, depending on the declinations of the source) are reduced by less than 5 per cent.*

The effectiveness of this system is illustrated in Figure 7 which shows records of the same region of the sky using the total noise system and the automatic gain control system.

* The system produces a small phase shift on the fringes. Correction for this is necessary in accurate measurements of the position of a source.

A block diagram of the units of the automatic gain control system in present use is shown in Figure 8. A push-pull output from the integrator is used to control the gains of the two radio-frequency stages in an electronic switch, one of which is connected to the aerial and the other to a reference load. The electronic switch and synchronous rectifier are components of a rapid inter-comparison system introduced by Dicke (1946), but are not essential requirements

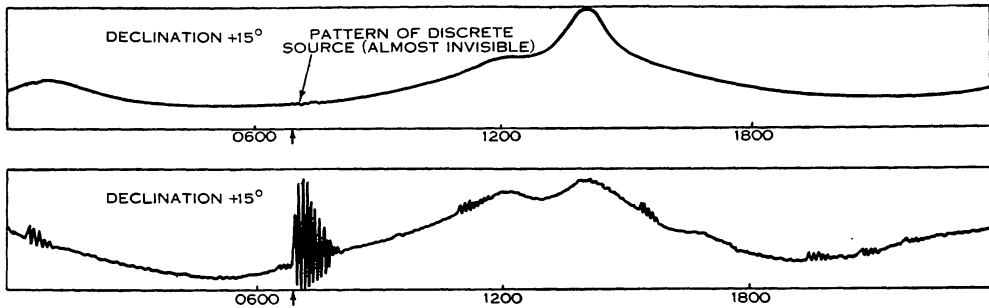

Fig. 7.—Records demonstrating the effectiveness of the automatic gain control system. The upper record is a normal total noise record and the lower is one of the same region obtained using the automatic gain control system. Note that the amplitudes of the interference patterns due to discrete sources are increased by a factor of about a hundred while the swing due to variations in the background noise is about the same.

of the equipment, as the control voltage from the integrator could be applied at a number of other places in the receiver. The inclusion of the switch prevents unwanted receiver gain variations affecting the operation of the integrator and permits a combination of the beam switching and automatic gain control systems to be used when required.

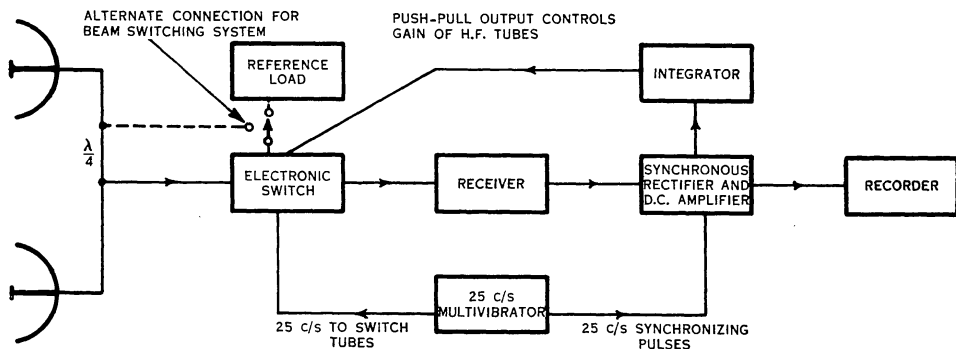

Fig. 8.—Block diagram of the automatic gain control system.

(d) *The Azimuth Interferometer*

In this system two aerials spaced along a cliff edge are used. The spaced aerials produce a second set of interference fringes at right angles to the normal sea interference fringes. The two aerials are connected to the receiver alternately in and out of phase, thus switching the azimuth fringe system through half a fringe width. A synchronous rectifier at the receiver output detects only

signals due to sources or irregularities in the background distribution smaller than the angular separation of the azimuth fringes. Complete elimination of the background noise can be achieved if sufficiently large aerial spacings are used.

The stages in the development of the system now in use are illustrated in the idealized records of a source rising shown in Figure 9. Figure 9 (a) is a standard sea interference pattern superimposed on a varying background level, as is obtained with a single aerial. Figure 9 (b) results from the combination of two aerials separated by a distance less than twice the cliff height. Phase switching in the two-aerial system eliminates the background noise giving the pattern of Figure 9 (c). However, the time taken for the generation of the azimuth fringes leads to difficulties in the interpretation of the results, particularly when there is more than one source in the aerial beam. This difficulty is

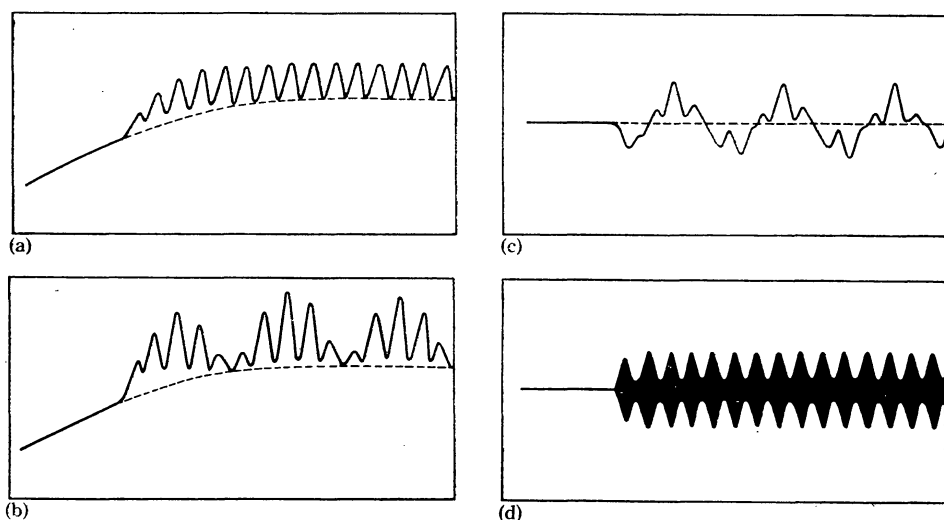

Fig. 9.—Diagrams illustrating the development of the azimuth interferometer. (a) Single aerial, total noise system; (b) two aerials, total noise system; (c) two aerials, phase switching system; (d) two aerials, phase switching and beam swinging.

overcome in a further development (Fig. 9 (d)) in which the azimuth fringe system is swung rapidly backwards and forwards through one fringe width. Here the envelope of the pattern is filled in by the rapid movement of the recorder pen.

A schematic diagram of the equipment is shown in Figure 10. The fringe swinging is achieved by varying the relative phase of the local oscillator to the two mixers by means of variable length lines. Artificial lines are used consisting of fixed inductances and variable capacitances which are driven by a small electric motor. The saturated amplifiers are to prevent the changing impedance of the lines dragging the frequency of the local oscillator or affecting the mixer stages. The phase switching is carried out at the intermediate frequency by means of quarter- and half-wavelength cables and an electronic switch.

Elimination of the background noise in the azimuth interferometer means that use can be made of relatively high-order fringes in making measurements of the angular sizes of sources. To obtain high resolving power observations have to be made from high cliffs where imperfect reflection from the Earth's curved surface affects the first few fringes. In the total noise system, measurements on the high-order fringes require an accurate knowledge of the background level. Its removal by the azimuth system overcomes this difficulty.

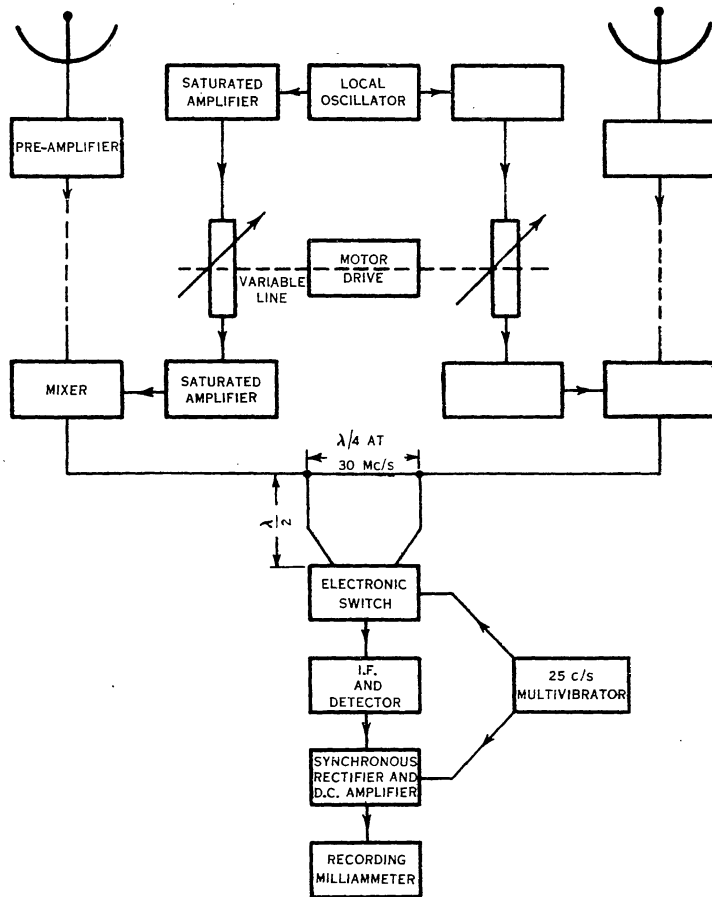

Fig. 10.—Block diagram of the units of the azimuth interferometer.

The azimuth interferometer with its dual fringe system has been found to be of considerable value in the study of extended sources of galactic noise (Bolton 1952). These observations and observations with the other forms of the sea interferometer will be described in subsequent papers.

IV. REFERENCES

- BOLTON, J. G. (1952).—Extended sources of galactic noise. U.R.S.I. Report 1952.
 DICKE, R. H. (1946).—*Rev. Sci. Instrum.* **17**: 268-75.
 MASSACHUSETTS INSTITUTE OF TECHNOLOGY RADAR SCHOOL (1946).—“Principles of Radar.”
 2nd Ed. (McGraw-Hill: New York.)
 RYLE, M. (1952).—*Proc. Roy. Soc. A* **211**: 351-75.
 STANLEY, G. J., and SLEE, O. B. (1950).—*Aust. J. Sci. Res. A* **3**: 234-50.